

**STUDY MATERIAL FOR THE  
CERTIFICATE OF FITNESS EXAMINATION FOR  
FIRE SAFETY COORDINATOR  
(Revised 8/16/2000)  
F-24**

This study material, in addition to any formal courses you have taken, will help you prepare for the examination for the Certificate of Fitness for Fire Safety Coordinator. The study material includes information taken from the Fire Prevention Code and the Fire Prevention Directives of the Bureau of Fire Prevention, NYFD. The study material does not contain all of the information you need to know in order to perform the job of Fire Safety Coordinator. In addition to other requirements of the position of Fire Safety Coordinator, it is your responsibility to become familiar with all-applicable rules and regulations of the City of New York, even if they are not covered in this material.

All questions on the Certificate of Fitness examination are multiple choice, with four alternative answers to each question. Only one answer is correct for each question. If you do not answer a question or mark more than one alternative your answer will be scored as incorrect. A score of 70% correct is required on the examination in order to qualify for the Certificate of Fitness. Read each question carefully before marking your answer. There is no penalty for guessing.

### Sample Questions

- \_\_\_\_\_1. The minimum water pressure at the level of the highest sprinkler head should be:
- (A) 15 psi.
  - (B) 25 psi.
  - (C) 50 psi.
  - (D) 100 psi.

The correct answer is "A". You would mark "A" on your answer sheet.

- \_\_\_\_\_2. When a gravity tank is required in a yard system the tank should be:
- (A) underground.
  - (B) on the ground level.
  - (C) elevated above ground level.
  - (D) filled with compressed foam.

The correct answer is "C". You would mark "C" on your answer sheet.

## RESPONSIBILITIES OF THE FIRE SAFETY COORDINATOR

A Fire Safety Coordinator is required in buildings occupied by more than 15 persons and used more than 30 days a year for housing. For example, a Fire Safety Coordinator is required in auditoriums, churches, schools, community centers, shelters, and other such buildings used for housing. This requirement does not include buildings such as hotels, motels, offices and apartment buildings. The Fire Safety Coordinator is hired by the program administrator or agency having charge of the occupancy to ensure that the **fire safety plan** is implemented and that all fire safety regulations are obeyed on the premises.

**Fire Safety Plan.** A fire safety plan must be filed with the Fire Department by the administrator or agency having charge of the shelter. This document must include a plan for fire drills and evacuation procedures, including a detailed description of what must be done in case of a fire emergency. The fire safety plan must be approved by the Fire Department. The applicable parts of the fire safety plan must be distributed to all employees in the shelter. A copy of the fire safety plan must be kept at the fire command post. This document is also called the “Critical File”. The Fire Safety Coordinator must also develop and implement and supervise all fire prevention and fire protection programs on the premises.

When the Fire Safety Coordinator is absent a deputy must assume the role of Fire Safety Coordinator. **The Fire Safety Coordinator must have a strong understanding of fire fighting and fire protection techniques.** He/she must know the location of and how to operate all fire protection devices in the shelter. In addition, he/she must make sure that these devices are in good working order at all times.

In case of a fire emergency the interior fire alarm system must be activated if necessary. After the alarm has been sounded the Fire Department must be notified. The Fire Department may be contacted by telephone or radio. There must be at least two separate ways to communicate with the Fire Department.

The telephone numbers of the local firehouse and the Fire Department Borough Communication Office should be known. The telephone numbers must be posted near the phones most likely to be used in case of an emergency. The borough communication offices phone numbers are listed below.

Manhattan	(212) 999-2222
Bronx	(718) 999-3333
Brooklyn	(718) 999-4444
Queens	(718) 999-5555
Staten Island	(718) 999-6666

The Fire Safety Coordinator must know the location of all fire protection devices, and interior and exterior fire alarm pull stations. At least one interior fire alarm pull station is required on each floor of the premises. In larger buildings the fire alarms pull stations must be spaced so that the distances between pull stations does not exceed 200 feet. They are positioned at the natural exits on each floor of a building. They must be securely mounted to the wall between 3.5 and 5 feet above the floor level. The fire alarm pull stations must be painted **red**.

The Fire Safety Coordinator must know how to conduct fire drills, evacuations and related activities such as organizing and training of subordinates. Generally, the Fire Safety Coordinator supervises deputy Fire Safety Coordinators and the fire guards. Each of these subordinates has specific duties to perform during emergency situations. The Fire Safety Coordinator must make sure that they are trained and can perform the required duties satisfactorily.

**The main responsibility of the Fire Safety Coordinator is to man the fire command post** during fire emergencies. The fire command post must be located in the lobby area. From this location the Fire Safety Coordinator must supervise the evacuation of the building according to the fire safety plan. For example, the Fire Safety Coordinator might instruct the fire guards to direct occupants of a building toward a stairway free of smoke or fire. Occupants on the fire floor and the floor above must be

evacuated immediately. Occupants on these floors are most seriously threatened by the spread of the fire. Occupants may exit the building or move to a floor below the fire floor.

The Fire Safety Coordinator must obtain as much information as possible about the fire from the fire guards. He/she may communicate with them using a telephone or a walkie-talkie. This information must be passed on to the Fire Department upon arrival. The Fire Safety Coordinator should stay in constant communication with fire guards during fire and non-fire emergencies.

When elevators are installed the Fire Safety Coordinator must return all elevators serving the fire floor to the ground floor. The elevators will then be used by Fire Department personnel when fighting the fire. The entire lobby area must be cleared and all entrances wedged open. The central air conditioning system must be shut down to prevent the spread of the fire. If there is one in the premises, the building engineer must be summoned to the fire command post. The building engineer must answer any questions asked by the Fire Department.

The Fire Safety Coordinator must have several items available for fire department personnel when they arrive. These are:

- (a) fire safety plan for the building;
- (b) floor plans;
- (c) window keys (as needed);
- (d) building master keys;
- (e) firefighter service elevator keys (6).

The Fire Safety Coordinator must remain composed and in control of the situation during an emergency. He/she must issue instructions in a clear and concise manner. His/her behavior has a major influence on the behavior of others during an emergency. Others are less likely to panic when they perceive the Fire Safety Coordinator is in control of the situation. If a fire occurs, the Fire Safety Coordinator must remain calm and instruct the occupants to remain calm during the evacuation.

In case of a fire emergency the Fire Safety Coordinator must activate the interior fire alarm system and notify the Fire Department. The Fire Department may be contacted by phone, or radio. The Fire Safety Coordinator must make sure that he/she and the fire guards know how to activate each of the fire alarm pull stations on the premises.

The Fire Safety Coordinator must ensure that all exits, hallways, and staircases are kept free of obstruction at all times. The aisle space between beds must be at least three feet (36 inches) wide. The aisle space in the main hallways (cross aisles) must be at least four feet (48 inches) wide. This aisle space is necessary to permit occupants to quickly exit the premises in case of an emergency.

## **SPRINKLERS AND SPRINKLER SYSTEMS**

Sprinkler systems are required by law in many buildings. For example sprinkler systems are required in theaters, hotels, motels, office buildings, and shelters. Sprinklers also may be installed voluntarily by an owner or occupant to protect a building, its contents, its occupants, or to obtain a reduction in insurance premiums. Sprinklers are devices for automatically distributing water on a fire. The intent is to extinguish the fire entirely, or to prevent the spread of the fire if the initial fire is out of range of the sprinklers. The installation of sprinklers has a pronounced effect in reducing fire losses. A study of recent records showed that sprinklers either extinguished or held in check 96 % of the fires in which they were involved.

Most sprinkler systems have a mechanism that automatically sound an alarm in case of sprinkler operation. Generally, the alarm is sounded on the premises. An alarm may be sounded at a remote location also. For example, the alarm may be sounded at a central station company. The Fire Safety Coordinator should know where the shut-off valves are for the sprinkler system components in case the

sprinklers discharge accidentally. The shut-off valve chart should be made available to Fire Department personnel upon request.

**Automatic Sprinkler Systems.** An automatic sprinkler system consists of a series of pipes at or near the ceiling of each story of a building. The pipes are filled with water or compressed air, and equipped with automatic devices to release water for fire fighting. These devices are called sprinkler heads.

Automatic sprinklers are particularly effective for life safety because they give warning of the existence of fire and at the same time apply water to the burning area. With sprinklers there are seldom problems of access to the seat of the fire or of interference with visibility for fire fighting due to smoke. The downward force of the water discharged from sprinklers lowers the smoke level in a room where a fire is burning. The sprinklers also serve to cool the smoke and make it possible for persons to remain in the area much longer than they could if the room were without sprinklers.

**Non-Automatic Sprinkler Systems.** Under normal conditions the pipes in the non-automatic sprinkler systems are dry. Water is supplied when necessary by pumping water into the system through the siamese connection.

### SPRINKLER HEADS

Sprinkler heads are made of metal, and are screwed into the piping at standard intervals. The standard sprinkler head has a 1/2 inch opening through which the water is discharged. The sprinkler head is held closed by an arrangement of soldered levers and links. This prevents the discharge of water until it is needed because of a fire. The solder is designed to melt when the temperature in the room reaches a predetermined level. When the solder melts the levers and links separate and the sprinkler head opens. When the sprinkler head opens it permits the discharge of water onto the fire. When the solder melts and the sprinkler opens, the sprinkler head is said to have "fused". A typical fusible link type sprinkler head is shown below.

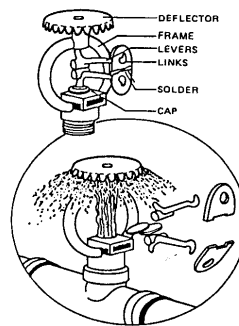

**A Typical Sprinkler Head**

Care must be taken to make certain that no part of an automatic sprinkler head is damaged when a room or the piping is painted or whitewashed. Paint on the sprinkler head could interfere with the free movement of the links and levers. This would delay the opening of the sprinkler head and prevent the discharge of water. The manufacturer may have painted part of the sprinkler head. If any other paint gets on the sprinkler head it must be replaced. The sprinkler head must also be replaced when foreign material has accumulated on it. The accumulation of foreign material on the sprinkler head is commonly referred to as a **"loaded sprinkler head"**.

Automatic sprinkler heads have various temperature ratings indicating the temperature at which they are designed to operate. The temperature rating of all solder-type automatic sprinkler heads is stamped on the soldered link. For other heat sensitive units, the temperature rating is stamped on one of the releasing parts. The temperature ratings of various heads are also color-coded. Care must be taken to make sure that fused or damaged sprinkler heads are replaced with sprinkler heads of the same rating. Mixing sprinkler heads with different ratings could result in extensive damage. The following table shows typical temperature ratings and classifications.

<b>TEMPERATURE RATINGS °F.</b>	<b>TEMPERATURE CLASSIFICATION</b>	<b>FRAME COLOR</b>
135 to 170	Ordinary	Unpainted (or partly black or chrome)
175 to 225	Intermediate	White*
250 to 300	High	Blue
325 to 375	Extra High	Red
400 to 475	Very Extra High	Green
500 to 575	Ultra High	Orange
*The 135° sprinklers of some manufacturers are half black and half painted. The 175° sprinklers of those same manufactures are yellow.		

### **TYPICAL SPRINKLER HEADS TEMPERATURE RATING AND CLASSIFICATIONS**

A supply of at least six extra appropriate sprinkler heads must be kept available on the premises. These extra sprinkler heads must be stored next to the main control valve for the sprinkler system. Fused or damaged sprinklers heads should be replaced promptly. Any head that has opened or has been damaged must be replaced immediately with a good sprinkler head.

A sketch of the entire sprinkler system must be kept readily available. This sketch must indicate the location of all control valves in the sprinkler system. The Fire Department may need this sketch during fire emergencies.

While sprinkler systems are an excellent means of controlling fires, they can add to the loss if they are not shut down at the proper time. However, control valves of the system may be closed only on orders of the fire officer in charge. The fire officer must decide that the fire is under control before shutting the control valves.

### **TYPES OF SPRINKLER SYSTEMS**

**Wet Pipe Sprinkler Systems.** Wet pipe systems have water in the piping at all times. This type of system is generally used wherever there is no danger of the water in the pipes freezing, and where there is no requirement for a special type of system. Where temperatures are below freezing, even for short periods of time, the ordinary wet pipe system cannot be used. The water would freeze and cause the piping to rupture. An illustration of a typical wet pipe system is shown on the next page.

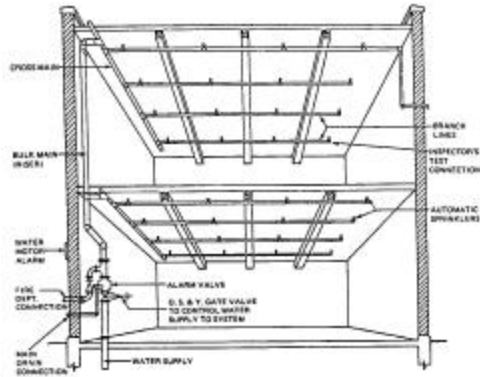

**A Typical Wet Pipe System**

**Dry Pipe Sprinkler Systems.** The second method uses a dry pipe valve. The dry pipe valve is installed where the water supply enters the sprinkler system. Piping in the sprinkler system is filled with air under pressure. Water is prevented from entering the piping by the dry pipe valve. The air pressure in the piping keeps the valve in the closed position. When a sprinkler head opens the air pressure is reduced and the valve opens. The dry pipe valve can also be opened manually in case of an emergency. The dry pipe valve must be housed in a heated enclosure to protect against freezing. An example of a typical dry pipe system is shown below.

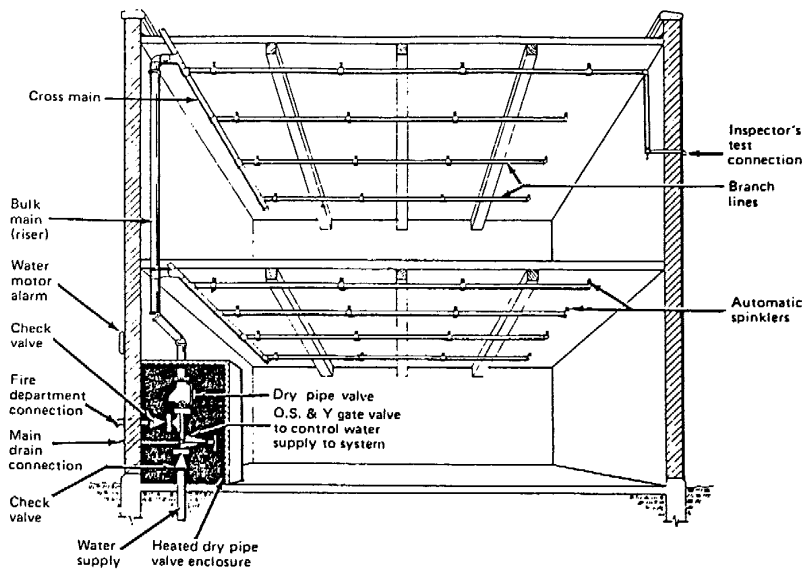

**A Typical Dry Pipe System**

### **Maintenance of Sprinkler systems**

There are two recognized methods of maintaining automatic sprinkler protection in locations exposed to freezing temperatures. The first method adds an antifreeze solution to the water inside the piping. This method is usually limited to small, unheated areas served by a wet pipe system where the piping would otherwise have to be shut off and drained during cold weather. Antifreeze solutions are costly and may be difficult to maintain. Antifreeze solutions may be used only in accordance with applicable local health regulations.

## STANDPIPE SYSTEMS

Standpipe systems provide water that firefighters can manually discharge through hoses onto a fire. Water is fed into a piping system. The piping runs vertically and horizontally throughout the building. The pipes running vertically are usually called risers. The risers are usually located in the staircase enclosures or in the hallways in the building. The piping system supplies water to every floor in the building. An illustration of a typical standpipe system is shown below.

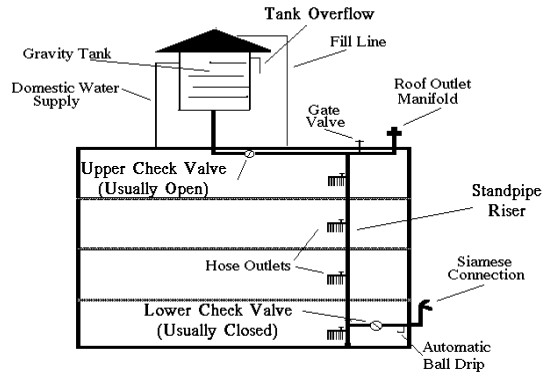

**A Typical Standpipe System**

Standpipe systems are used in buildings where it may be difficult for the Fire Department to pump water on the fire. For example, standpipe systems are required in buildings that are over 75 feet in height. The top of the standpipe riser extends up onto the roof. Three hose connections are attached to the top of the standpipe riser. These three connections make up the roof manifold. The roof manifold is used when extinguishing fires on the roof. It is also used when testing the water flow in the standpipe. An example of a typical roof manifold is shown in the picture below.

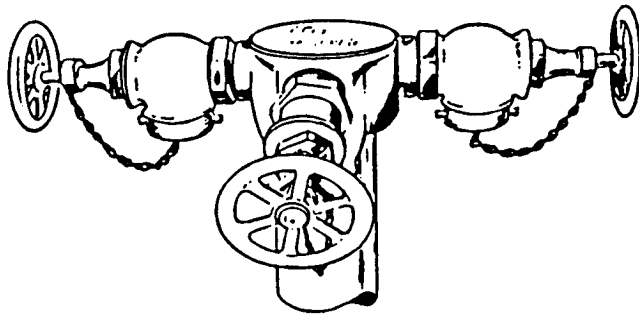

**A Typical Roof Manifold**

At selected locations in the building the piping is connected to a hose. Gate valves control these connections. No water is allowed into the hose until the valve is opened. The gate valve must be manually opened by the fire fighter. The hose is usually stored on a quick release rack. A nozzle is attached at the end of the hose. The nozzle is used to direct the stream of water from the hose. An example of a typical quick release rack is shown on the next page.



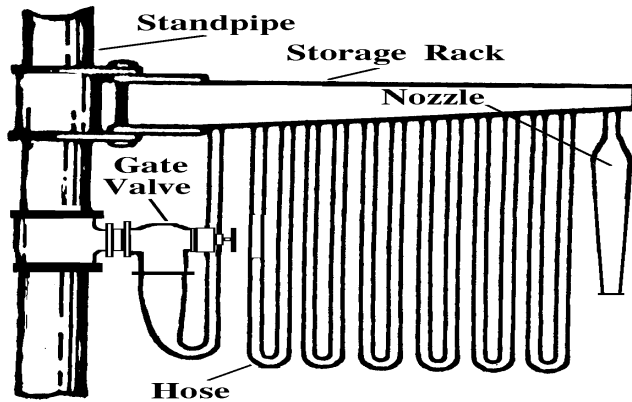

**A Typical Fire Hose Outlet and Release Rack**

The hose and nozzle must be accessible at all times. The hose outlets are located so that every part of the building may be reached with a hose stream. The maximum length of a single hoseline is 125 feet. Sometimes the hoses are installed in cabinets. If the hoses are installed in cabinets each cabinet should be labeled "**FIRE HOSE**". When the hose outlets are not easy to see, signs should be posted telling where the hose outlet is located.

A pressure-reducing device should be installed in the piping at each hose outlet. This device allows a maximum of 100 psi (pounds per square inch) of water pressure to flow into the hose. It is dangerous if the water pressure is too high. An occupant of the building may be injured if a hose is used when the pressure-reducing device is not installed. During an emergency the fire fighter may remove the pressure-reducing device.

Each standpipe system is also fitted with a drain valve. The drain valve is located at the lowest point on the standpipe system. The drain valve is used when the standpipe system is being tested or repaired. Under normal conditions the drain valve is sealed in the closed position.

OS&Y (Outside Stem and Yoke) gate valves are installed at several places in the system. The OS&Y valves can be used to shut down part of the standpipe system. Sections may be shut down for testing, repairs or maintenance. The stem of an OS&Y valve must be kept in the extended (open) position at all times. A typical OS&Y valve is shown below.

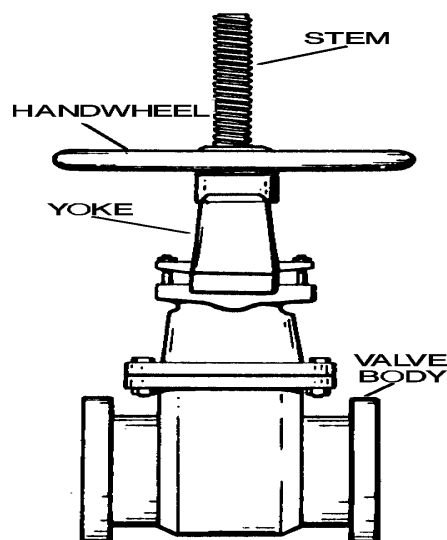

## TYPES OF STANDPIPE SYSTEMS

**Wet Standpipe.** This system always has water under pressure in the piping. In some cases a fire pump may be used to increase the water pressure. The wet pipe system is most commonly used in heated buildings where there is no danger of the water in the piping freezing. Any part of the standpipe system that is exposed to freezing temperatures should be insulated or heated.

**Dry Standpipe with an Automatic Dry Pipe Valve.** This system is usually installed in unheated buildings. Under normal conditions there is no water in the standpipe. Instead, there is air under pressure in the standpipe. A dry pipe valve is installed to prevent water from entering the standpipe. This valve is designed to automatically permit water into the standpipe when a hose is opened.

## CLASSES OF STANDPIPE SYSTEMS

Standpipe systems are classified depending on who is expected to use the system and the size of the fire hoses in the system. The three classes are briefly described below.

**Class I.** This system is designed to be used by trained fire fighters. For example, Fire Department and especially trained personnel use the system. The fire hoses in these systems are 2½ inches in diameter. The large hose diameter makes it difficult to control the stream of water from the hose.

**Class II.** This system is designed to be used by the occupants of a shelter. The hose and nozzle are connected to the standpipe. They are ready to be used by occupants in case of a fire. The hose is 1½ inches in diameter. The hose stream is easier to control than the Class I hose.

**Class III.** This system may be used by either trained fire fighters or by occupants of the shelter. The hosing may be adjusted to either 1½ or 2½ inches in diameter. This is done by attaching special pressure-reducing valves to the hose line.

## WATER SUPPLY METHODS FOR SPRINKLER AND STANDPIPE SYSTEMS

The same general methods are used to supply water to sprinkler and standpipe systems. Sprinkler and standpipe systems may be supplied from one or a combination of sources, such as public water mains, gravity tanks, pressure tanks, fire pumps, reservoirs, rivers, lakes, wells, etc. A single water supply would appear to be all that is necessary for satisfactory protection, provided the volume and pressure are sufficient. However, a single supply may be temporarily out of service. It may be disabled at the time of the fire or before the fire is extinguished; or the pressure or capacity may fall below normal during an emergency. Adequate secondary or additional water supplies may therefore be advisable or necessary. This depends on the strength and reliability of the primary supply, the value and importance of the property, the height, area and construction of the building, its occupancy and the exposures, or legal requirements.

City water connections from large mains, fed two ways, or connections from two mains on a gridiron system with adequate pressure may provide an excellent and completely satisfactory supply for the sprinkler and standpipe systems. When a sprinkler or standpipe system is supplied from a public water main, operating a control valve between the building and the water main may close down the entire system. This shutoff valve is frequently located in a box that is recessed in the sidewalk. The location is designated by a sign on the building or post nearby reading "**Shutoff for Sprinkler System Located 6 Feet from This Sign**" or similar instructions. A special key may be required to operate this valve.

The water main supply for sprinkler and standpipe systems may also be controlled by valves of the OS&Y type which are found just inside the building wall on the main riser, or outside in protected pits. It is possible to tell at a glance if the valve is open or shut because the stem is all the way out (**extended position**) when the valve is open. **When the stem is all the way in the valve is closed.**

Additional OS&Y valves may be used to control the supply for individual floors, and separate valves may be installed to shut off certain sections of a floor. In many cases, parts of a system subject to freezing are isolated in cold weather by closing the OS&Y valve and draining the pipes.

**Siamese Connections for Fire Department Use.** Normally sprinkler and standpipe systems are connected to an automatic source of water supply. Auxiliary sources of water are supplied through siamese connections at the building. Fire Department siamese connections are therefore a standard part of sprinkler and standpipe systems. When responding to an alarm, the Fire Department will supply the standpipe system first, if one is present, and then stretch one or more lines to the siamese connection. Care should be taken that connections are properly identified.

Since the connections for standpipe systems and sprinkler systems are alike in appearance. The exact purpose of each connection should be indicated nearby or on the siamese itself. The Building Code requires that the protective caps to siamese connections be color-coded. The siamese connection caps to an automatic sprinkler system should be painted green. Aluminum should be used for a nonautomatic sprinkler. A standpipe system is indicated by red caps, and yellow caps indicate a combination standpipe/sprinkler system.

Fire Department connections must be readily accessible, and properly marked. Each connection should be fitted with a check valve. The check valve prevents the backflow of the private water supply into the public water supply. The automatic drip device between the check valve and the outside hose coupling prevents water from building up in the piping. This drip device makes sure that fire department connection is not blocked by water that has frozen in the piping. When the automatic ball drip on a sprinkler siamese connection leaks under normal conditions indicates that the check valve may be defective.

**Connections to Public Water Works System.** A connection from a reliable public water works system of adequate capacity and pressure is the preferred single or primary supply for an automatic sprinkler systems and a standpipe system.

**Gravity Tanks.** Gravity tanks of adequate capacity and elevation make a good primary supply and may be acceptable as a single supply. A diagram of a gravity tank is included in Appendix A.

**Fire Pumps.** A fire pump having both a reliable source of power and a reliable suction water supply is a desirable piece of equipment. Fire pumps are commonly used because of the advantages of hydraulically pumping water, under high pressure, into the sprinkler or standpipe system. With ample water available a fire pump is capable of maintaining a high pressure over a long period of time. Manually controlled pumps may be used if the primary water supply will last long enough to allow dependable starting of the fire pump and if there is an automatic waterflow signal to indicate the need for fire pump operation. Automatic control of fire pumps is usually needed where a high water demand may occur immediately, as with a deluge system, or where a competent pump operator is not continuously present. Automatic fire pumps must have their suction under a positive head to avoid the delays and uncertainties of priming. When testing the pressure of fire pumps, the hydrostatic pressure should be at 50 psi at the top of the hose outlet. A diagram of a fire pump is included in Appendix A.

**Pressure Tanks.** An important limitation is the small volume of water that can be stored in such tanks. Where a small pressure tank is accepted as the water supply, the system is classified as a "limited supply system". Pressure tanks have several possible uses in the fire protection system. Pressure tanks are often used in situations where an adequate volume of water can be supplied by a public or private source but where the pressure is not sufficient to serve the sprinkler or standpipe system directly. The pressure tank gives a good starting pressure for the first sprinklers that have fused or the first standpipe hose that is operated. The flow from the tank may be used while the fire pumps start automatically to increase the supply pressure. Pressure tanks are generally used in tall buildings where the public water pressure is too low for effective water distribution throughout the sprinkler system. A diagram of a pressure tank is included in Appendix A.

All water supplies must be protected against freezing temperatures. This may be achieved by heating the water or by insulating the parts of the system exposed to the freezing temperatures. This is essential because an entire fire protection system may be rendered inoperative if the water is frozen in part of the system.

## **COMBINATION STANDPIPE AND SPRINKLER SYSTEMS**

A building may have both a standpipe and a sprinkler system installed. Each system may have its own water supply source. For example, the standpipe system may be supplied by a gravity tank and the sprinkler system supplied by a pressure tank.

It is quite common for the two systems to share the same water supply source. For example, both systems may use the same gravity tank as a water supply source. The gravity tank is a limited water supply. The amount of water that is allocated to each system is regulated by local building laws. The caps on a siamese connection supplying a sprinkler and a standpipe system must be painted yellow. A sign indicating that the Fire Department connection supplies both systems must also be posted.

## **INSPECTION AND MAINTENANCE**

The sprinkler and standpipe systems must be regularly inspected to make sure that they are working properly. All parts of the sprinkler and standpipe system must be visually inspected monthly. These visual inspections should make sure that the system is free from corrosion and physical damage. Special attention should be given to any evidence of tampering with the fire protection system. Any part of the system that is damaged or missing should be repaired or replaced immediately.

All valves and connections to the automatic water supply sources should be inspected weekly. The valves should be checked to make sure that they are in the correct position. The valves should also be labeled to show their correct position and purpose. The Fire Department should be notified when any part of the system is shut down for maintenance or repairs. A sign should be posted indicating that the section is shut down. All Fire Department siamese connections must be tested at least once every 5 years. The standpipe system must also be subjected to a flow and pressure test to demonstrate that it is suitable for Fire Department use. This test is conducted by the agency's representative and witnessed by a Fire Department inspector.

Valves, hoses, tools, and other fire fighting appliances must be kept readily available and in good working order. Fire pumps must be operated at least once every thirty days in a manner that will subject the standpipe system to a hydrostatic pressure of at least fifty (50) pounds per square inch at the top story hose outlet. A record must be kept of all inspections.

All major defects in the system must be immediately reported to the local firehouse. The program administrator or agency in charge of the occupancy and the Bureau of Fire Prevention should also be notified. Major defects include: an empty tank, a break or a leak in the system water piping, an inoperative or shut water supply valve and a defective siamese connection. The defects should be corrected immediately. A complete or partial shutdown of the standpipe system for repairs or any other reason must also be reported. This will allow the Fire Department to modify its fire fighting strategies for the building.

Minor defects should be reported to the program administrator or agency in charge of the occupancy. Minor defects should be repaired within 30 days. If the defects are not corrected within 30 days, they must be reported to the Bureau of Fire Prevention.

The date of all inspections, maintenance and repairs made on the system must be recorded on the inspection record card. The record should also include the Certificate of Fitness number and the signature of the Fire Safety Coordinator or his/her deputy. This record must be posted near the main

control valve. All records must be kept for a period of at least one year. They should be made available to any representative of the Fire Department upon request.

## FIRE ALARM SYSTEMS

Fire alarm systems are required in many locations as part of a fire protection system. For example, alarm systems are required in hotels, motels, shelters, hospitals, office buildings and marinas. If a fire emergency occurs the alarm system warns the occupants of the building. Loud sirens, gongs or bells are used to signal when there is a fire. Some fire alarm systems also use flashing lights. The sirens, gongs, bells and flashing lights are commonly called the signaling devices. A signal indicating that there is a fire may also be sent to an approved central station company.

**Manually Activated Fire Alarms.** Some fire alarms are activated automatically. Special sensors detect heat or smoke and sound an alarm. Other fire alarms must be activated manually. A person who notices a fire emergency must activate the alarm by hand. Fire alarms that are manually activated use fire alarm pull stations. Fire alarm pull stations are usually located near the natural exits from a building. There are two types of fire alarm pull stations. They are called single action and double action pull stations.

**Single Action Pull Stations** require only one step to activate the alarm. For example, the alarm might be activated by pulling down on a lever. Two examples of a single action pull station are shown below. These two kinds of alarm pull stations are often found indoors, e.g., in office buildings. The cover on these alarm pull stations serves as a lever. When the cover is pulled down, it allows a switch inside to close. This sends the alarm signal. The alarm pull station on the right is often called a "breakglass station." Another kind of single action breakglass station requires someone to break a small pane of glass with a small metal mallet.

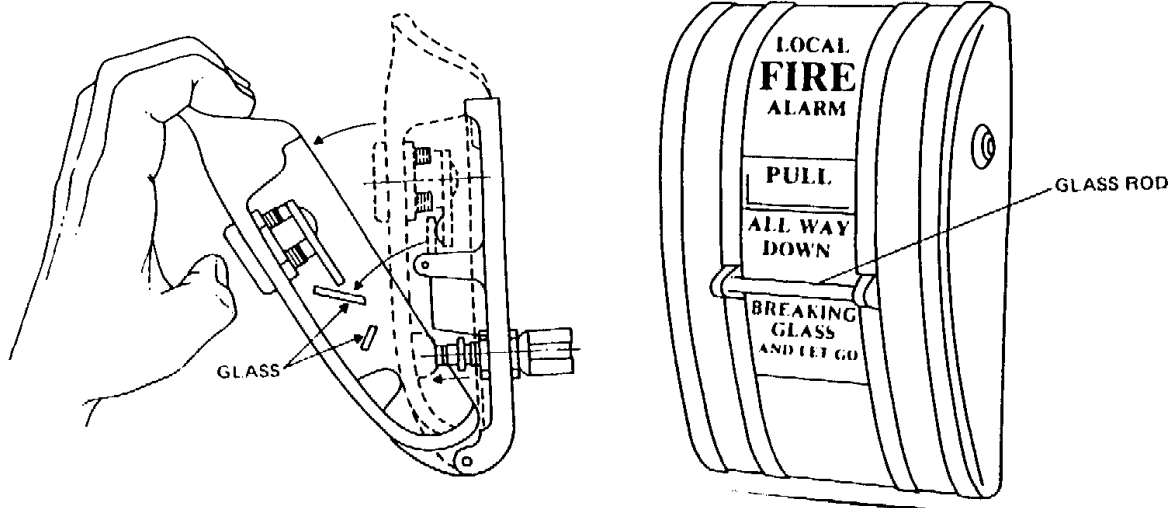

**Single Action Station**

**Double Action Pull Stations** require two steps in order to activate the alarm. The user must first break a glass, open a door or lift a cover. The user can then gain access to a switch or lever that must then be operated to initiate an alarm. One kind of double action pull station is shown below. To activate this fire alarm pull station the cover must be lifted before the lever is pulled. This kind of double action pull station is often found indoors.

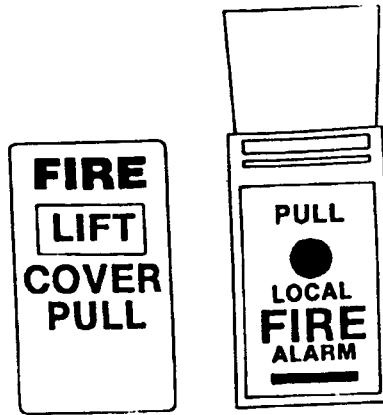

**Double Action Stations**

The fire alarm pull stations used to activate the fire alarm system are called initiating devices. The Fire Safety Coordinator must know how to manually operate each fire alarm pull station on the premises. Once activated, the fire alarm system can not be shut off at the fire alarm pull station. The alarm must be shut off at a main control panel using a special key. This key must be kept near the control panel at the fire command post at all times. The alarm may be turned off only by Fire Safety Coordinator or by a Fire Department representative.

A silencing switch may be installed in the fire alarm system. Under special circumstances the silencing switch may be used to turn off part of the system. For example, The silencing switch may be used to turn off the sirens and bells after the building has been evacuated. However, the silencing switch does not prevent a signal from being transmitted to an approved central station company.

**Automatically Activated Fire Alarms Systems** sound a signal when a fire detection device indicates that there is a fire. Special sensors detect heat, smoke or the flow of water. These sensors are the initiating devices in automatic fire alarm systems. A few of the more common initiating devices are described below.

Waterflow alarms are designed to signal when water flows through the fire protection system. For example, a waterflow indicator signals when water flows through the piping in a sprinkler system. Waterflow in the sprinkler system may be detected using one of two methods. These methods use vane type waterflow indicators or special check valves.

**Vane type indicators** are installed inside the piping of the fire protection system. The vane indicators are usually installed close to the main control valve. When the water flows through the piping it moves the vane. The movement of the vane causes a signal to be transmitted to the alarms. When the signal is transmitted the alarm is sounded. A signal may also be transmitted to a central station company. An example of a vane type indicator is shown in the next page. The diagram on the left shows the vane position when water is not flowing through the piping. The diagram on the right shows the position of the vane when water flows in the piping. When the vane moves it closes a switch and a signal is sent.

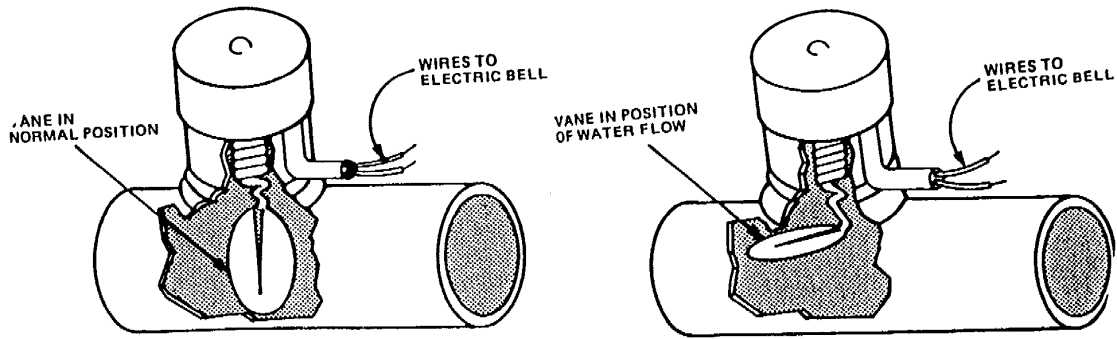

### Vane Type Waterflow Indicator

**The check valve** is designed to detect when water flows into the protection system's piping. The valve is installed at the location where the water supply enters the fire protection system. A clapper mechanism is located inside the check valve. Under normal conditions the clapper is in the closed position. When in the closed position the clapper prevents water from flowing into the piping. The clapper mechanism opens when there is a demand for water in the fire protection system. For example, the clapper will open when a sprinkler head opens to discharge water. When the clapper opens it allows water into the system piping. It also allows water to flow into a chamber that leads to the waterflow gong. When the water flows into this chamber it causes the gong to sound. An illustration of a check valve is shown below.

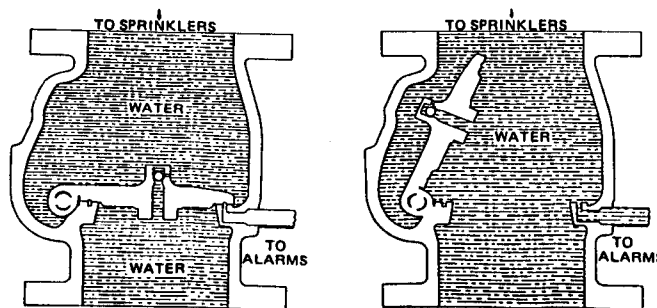

### Check Valve with a Connection to the Waterflow Gong

**Smoke detectors** sound an alarm when smoke is detected in the building. Smoke detectors have been shown to be very effective in reducing fire damage. An example of a ionization smoke detector and its components is shown on the next page.

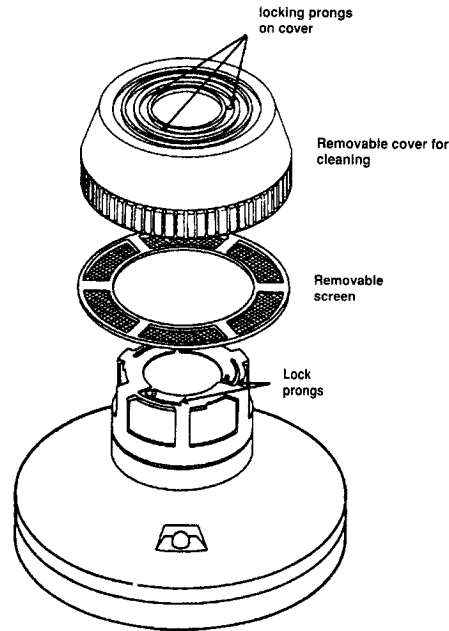

## Smoke Detector

Smoke detectors may be installed on walls or ceilings. When installed on the wall they must be located between 4 and 12 inches from the ceiling. When installed on the ceiling they must be located at least 4 inches from the wall. The smoke detectors must also be located at least 3 feet from any heating vents. This prevents the air coming from the vents from blowing the smoke away from the detectors. The smoke detectors should never be installed in the corner of a room. In multistory buildings smoke detectors must be installed on every landing in the stairwell.

**Heat Detectors** are sensors that detect high temperature levels. There are two types of heat detectors: fixed-temperature and rate-of-rise detectors. The fixed temperature heat detectors are most commonly used. These detectors consist of two electrical contacts housed in a protective unit or box. The contacts are separated by a fusible element. The element melts when the temperature in the room reaches a preset level. This allows the contacts to touch. When the contacts meet the detector activates the fire alarm. The fixed temperature heat detectors must be replaced after they have sounded an alarm.

The rate-of-rise heat detectors activate the alarm when the room temperature increases at a certain rate. This kind of detector is more sensitive than the fixed temperature detector. The rate-of-rise heat detector does not have to be replaced after it has activated the fire alarm.

Regardless of what kind of detector is installed, heat detectors require special attention. All heat detectors must be carefully installed according to the manufacturer's instructions.

## Trouble Alarms

Supervisory devices are installed as part of some fire protection systems. The supervisory devices monitor important parts of the system. An alarm will be sounded when there is a problem or trouble with part of the system. For example, a signal will be sounded when a control valve is damaged or when it is in the wrong position. This kind of signal is commonly called a trouble signal. The trouble signal is always transmitted to the main control panel. The trouble signal may be transmitted to a central station company also.



Some fire control panels indicate the exact location of the trouble. Other panels only display a general trouble signal. For example, a lighted panel might indicate only that there is a problem somewhere in the fire protection system. Each supervised device must then be inspected to determine which part is causing the trouble signal. When a trouble signal is detected the problem causing the trouble signal should be corrected immediately. Some parts of the fire protection system that are commonly supervised are:

1. Water control valves
2. Water temperature in gravity and pressure tanks
3. The water level in the gravity and pressure tanks
4. The pressure level in the tanks
5. The power supply for the fire pump

Both trouble and fire alarms must be treated as fire emergencies. The Fire Safety Coordinator must notify the Fire Department immediately whenever an alarm signal is detected. It should never be assumed that any alarm is "only" a false alarm.

### **Transmission of Fire Alarms**

There are three methods used to notify the occupants of a building in case of a fire. The first method is the general alarm method. This method activates all signalling devices throughout the building when a fire is discovered. The second method is the selective method. The selective method activates the signalling devices only in areas close to the fire. The third method is the pre-signal system. The pre-signal method sends a signal to a control panel or a manned station. When the signal is detected the Fire Safety Coordinator must investigate the cause of the alarm. When a fire is discovered the Fire Safety Coordinator must manually activate the general fire alarm. The general fire alarm is activated by inserting a key into the control panel at the fire command post.

After the fire alarm system has been activated it must be reset manually. The Fire Safety Coordinator must reset the alarm. The fire alarm system must be reset at the control panel. The fire alarm must remain in operating condition at all times unless the building is vacated for more than one week.

**Annunciator panels** are sometimes installed in large buildings. The annunciator panel is used to monitor the fire alarm devices in a designated fire zone. There may be several fire zones in a building. Each fire zone is marked clearly on the panel. When a fire occurs an indicator light flashes on the panel. The indicator light identifies the location of fire. For example the light on the panel might indicate that a fire has occurred in Fire Zone 2. This information allows the Fire Department to quickly locate the fire. An example of a typical annunciator panel is shown on the next page.

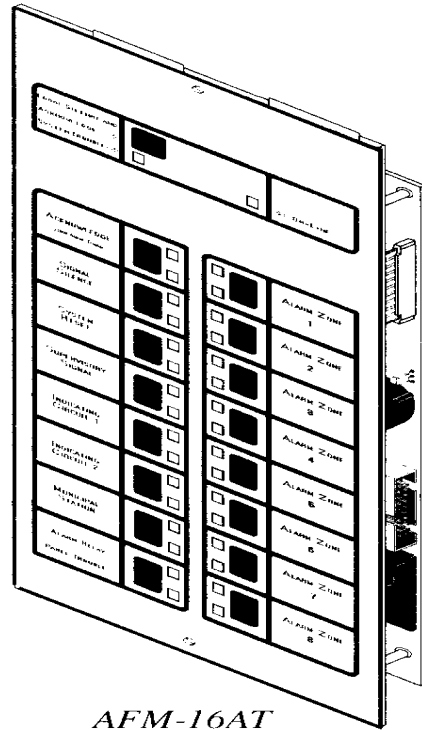

*AFM-16AT*

### **Annunciator Panel**

### **Communication System**

A dependable communication system is required as part of the fire alarm system. A two-way communication system is required in some fire alarm systems. Usually a type of telephone system is installed. Telephones must be placed at several locations in the building. The telephones are usually located in elevators and next to the stairways in the building. A telephone must also be installed in a command center. The fire command post is used to issue instructions during a fire emergency. Portable two-way radios may also be used as a means of communication.

Some buildings also have a public address system installed. The public address system may be used to warn and instruct building occupants in case of a fire emergency. All communication systems may be used to issue evacuation instructions in case of an emergency.

### **Maintenance**

The Fire Safety Coordinator must make sure that all parts of the fire alarm system are kept in good working order. When defects are discovered the Fire Safety Coordinator must have such defects repaired immediately. All repairs must be performed only by a licensed contractor.

When breakglass fire alarms are installed the Fire Safety Coordinator must make sure that an extra supply of glass plates are kept available. At least one extra glass plate is required for each fire alarm box. These extra glass plates must be stored on the premises.

Smoke detectors must be cleaned regularly. Since smoke detectors are extremely sensitive and easily damaged care must be taken when cleaning them.

The interior fire alarm pull stations and related equipment must never be painted. The paint may prevent the equipment from working properly. For example, a smoke detector may not be able to detect smoke after it has been painted.

Whenever a building is remodeled the fire alarm system must be checked to make sure that it is working correctly. For example, the system must be checked whenever partitions or walls are erected or taken down. When the fire alarm system has been damaged it must be repaired immediately. The Fire Department must be notified when any changes are made to the fire protection system.

## **Testing and Inspections**

The Fire Safety Coordinator must supervise the operation and testing of the fire alarm system. Each fire alarm system must be tested monthly. This test is called a “silent test” and the Fire Safety Coordinator conducts it. A special key on the control panel is used to conduct the silent test. This method determines if the entire system is functioning properly. If a defect is discovered a signal will sound. It also sends a signal to the central station company. Since the alarm system in the shelter is connected to a central station company, the central station company must be notified before making the silent test. Then the Fire Safety Coordinator must make sure that the signal was received.

The fire alarm system may also be used when conducting fire drills. The Fire Safety Coordinator must make sure that all signalling devices are working correctly. Special permission must be obtained to use the fire alarm system to signal the end of the work day. The Fire Commissioner may grant this permission. However, the fire alarm may not be used for any other purpose.

Initiating devices must be tested by the Fire Safety Coordinator at least once a month. These devices are tested by activating them in their normal manner. For example, the interior fire alarm pull stations must be activated by pulling down on the lever or turning the key at the alarm pull station. It is not necessary to test all devices individually. Instead, one initiating device of each type must be tested each month. A record must be kept to make sure that a different device is tested each time.

The Fire Safety Coordinator must ensure that the smoke detectors are tested once every six months by an individual holding a valid certificate of fitness for smoke detectors or a licensed electrician. Smoke detectors are tested by spraying a smoke detector test aerosol into the detection chamber. However, any source of smoke may be used when testing the smoke detection unit. All smoke detectors must be reset at least once a year. This procedure makes sure that the fire detector is kept in good working condition.

Heat detectors must also be tested. Rate-of-rise detectors are initially tested by a Fire Department representative. Any further testing is performed by the installing company. The fire alarm will be activated when the rate of increase is higher than acceptable levels. A licensed electrician conducts this test. When a defective detector is discovered it must be replaced immediately.

Fixed temperature heat detectors may not be tested using heat. Using a heat source would melt the device used to separate the electrical contacts; then the detector would have to be replaced. Instead, special testing methods are used. For example, heat detectors housed in a protective unit are tested by using insulated wire alligator clips. First, the detector is removed from the protective box, and then a clip is connected to each of the electrical contacts inside the detector. The fire alarm will sound if the detector is working correctly. If the detector is satisfactory the detector is replaced in the protective box. A licensed electrician or an individual holding the appropriate certificate of fitness conducts this test. Fixed rate detectors must be tested every 15 years.

Supervisory devices must be tested at least once a year. Disconnecting the appropriate wires from the control panel tests them. A trouble signal should light up at the control panel when the wires are disconnected. When the trouble signal sounds the supervisory device is working correctly. A licensed electrician or the appropriate certificate of fitness must disconnect and then reconnect the wires.

The entire fire alarm system must be visually inspected at least once a month. The Fire Safety Coordinator must conduct this inspection. Defective equipment must be replaced immediately.

The lights on the control and annunciator panels must be inspected daily. The Fire Safety Coordinator must locate and manually activate the “test button” on the panel. If any defective bulbs are discovered they must be replaced immediately. When an emergency power generator is installed the generator must be checked monthly.

A record of all tests, inspections, fire drills and other operations of the fire alarm system must be noted in a testing log. The Fire Safety Coordinator is responsible for this log. The Fire Safety Coordinator must keep the log in a safe location inside the building. The log must be made available to any representative of the Fire Department.

If any defects are discovered the Fire Safety Coordinator must have the defects repaired immediately. When the fire alarm system is shut down during repairs signs must be posted. These signs must indicate that the fire alarm system is not in operation. These signs must be posted at the fire alarm boxes inside the building. The Fire Safety Coordinator must notify all occupants in the shelter that the system has been shut down. The Fire Department must also be notified. This will allow the Fire Department to modify the fire protection strategy for the building. The Fire Department may conduct inspections of the fire alarm system. Summonses may be issued if any violations are discovered.

The main power supply for a fire alarm system may be provided by the local utility or by an engine driven generator. Connection to a local utility should be on a dedicated branch circuit. The primary power supply should be supervised and its failure indicated by a distinctive trouble signal. The fire alarm system should also have a reliable secondary (standby) power supply. The secondary supply should provide power to the alarm system within 30 seconds of failure by the primary power supply. Storage batteries or engine driven generators can provide standby power for the system.

## **FIRE GUARDS FOR SHELTERS**

Shelters offer overnight accommodation and some personal care services to those in need of aid. These shelters are designed to attend to the needs of many people including the homeless, elderly, battered persons, unwed mothers and runaway children. Generally, the shelters are designed to provide refuge for more than 15 people. A Fire Safety Coordinator and a fire guard are required in each shelter. They are responsible for the safety of all occupants in the shelter. They must make sure that all fire safety regulations are obeyed inside the shelter. The Fire Safety Coordinator *supervises* the fire guards assigned to the shelter. The safety fire coordinator is responsible for making sure that the fire guard performs his/her fire safety duties.

Generally, those employed in the shelter are required to wear an identification card. When an identification card is not issued the staff usually wears a distinctive cap or arm band. The ability to quickly distinguish between the staff and occupants of the shelter is extremely important. It permits the staff to be easily identified in case of a fire emergency. The occupants can then follow the instructions given by the staff during an emergency.

### **General Safety Requirements Inside the Shelter**

A current list of all physically challenged persons and their locations in the facility must be maintained and available for the Fire Department. This list should be kept at the fire command post. A fire command post is required in each shelter. Usually, a control panel for the fire protection system is located at the fire command post. The fire command post must be equipped with a walkie-talkie and a phone. The Fire Safety Coordinator will give evacuation instructions from the fire command post during a fire emergency. The fire guard will assist in the evacuation of occupants from the shelter. The fire guard may also need to investigate the cause of an alarm, and to use a fire extinguisher if the fire is small.

Several sleeping areas may be located in each shelter. These sleeping areas may be located anywhere in the building except the basement. Each sleeping area must be supervised at all times. The supervisor

must make sure that no smoking is permitted in the sleeping areas. Each sleeping area and dining area must be provided with at least two metal trash cans. These trash cans must have a tight fitting cover installed. The trash cans must be emptied at least twice daily. Rubbish awaiting collection must be stored outside the building or in a sprinklered room on the ground floor. There should be two waste receptacles per sleeping area, but not less than one waste receptacle for 50 persons in any one area.

Storage of flammable and combustible liquids in shelters must have special precautions. These precautions include that these hazardous materials be stored in non-combustible cabinets, have adequate ventilation and should be protected from flames and direct sources of heat.

Some of the most common sources of ignition in shelters are listed below.

- (1) Smoking
- (2) Defective electrical cords
- (3) Defective appliances
- (4) Improper use of electrical cords and appliances
- (5) Improper use of portable heating appliances

The fire guard should check to see if any of these dangerous conditions exist and to correct them if necessary. It is also important to note that some fires have been started intentionally. The fire guard must pay close attention to any kind of suspicious behavior. Any kind of suspicious behavior must be reported to the Fire Safety Coordinator. The fire guard must check all portable heating appliances regularly. They must be positioned at a safe distance from combustible materials. Several types of safety signs must be posted at various locations inside the shelter. The signs are designed to ensure the safety of occupants. These signs must indicate:

- (1) the location of emergency exits;
- (2) general safety procedures to be followed during an emergency;
- (3) how to use the fire extinguishers and related fire fighting equipment;
- (4) how to sound the fire alarm in case of an emergency;
- (5) that stairs should be used instead of the elevators in case of a fire;
- (6) that no smoking is permitted in the shelter.

The fire guard must make sure that safety signs are clearly visible at all times. Defective or missing safety signs must be replaced immediately.

## **Patrols**

The fire guards must patrol the entire fire shelter at least once every hour. During their patrol they must look for signs of fire. they must investigate any signs of smoke in the shelter. If any fire safety violations are discovered they must report them to the Fire Safety Coordinator. The Fire Safety Coordinator must then take action to correct the situation. For example, he/she must make arrangements to remove any accumulated rubbish. Breaks or leaks in the sprinkler system, no matter how small, must be reported to the Fire Department immediately. The fire guard should check the condition of fire protection equipment. For example, the fire guard should make sure that the fire department connection outside the shelter is kept free of all obstructions. The fire guard must keep a log of all patrols. This log should record the fire guard name and signature, the time and date of the patrol. The results of all patrols must be recorded in the log. For example, any safety violation must be recorded.

## **Emergency Procedures**

When a fire is discovered by the fire guard must sound the interior fire alarm. After the alarm is sounded the fire guard must contact the Fire Safety Coordinator. Generally, the Fire Safety Coordinator may be contacted by walkie-talkie. However, a telephone may be used if the fire guard does not have a walkie-talkie. The Fire Safety Coordinator will then tell the fire guard what to do

during the emergency. For example, the Fire Safety Coordinator may instruct the fire guard to evacuate the building. He/she will also indicate the safest route to be taken while evacuating the building. The fire guard must follow all of the instructions issued by the Fire Safety Coordinator. The fire guard must make sure that all occupants have evacuated the building.

## **Fire Drills**

**Fire drills must be conducted at least once a month on each shift.** These drills must be supervised by the Fire Safety Coordinator. Everyone in the building must participate in the fire drills. These drills must be conducted in an orderly manner in accordance with the fire safety plan. The fire guard will assist the Fire Safety Coordinator when the fire drill is conducted.

## **Safety Requirements**

Several types of safety signs should be posted at various locations inside the building. The signs are designed to ensure the safety of occupants. For example these signs may indicate:

- (a) the general fire safety procedures to be followed during a fire emergency;
- (b) the location of fire extinguishers and emergency exits;
- (c) how to use the fire extinguishers and related fire fighting equipment;
- (d) how to sound the fire alarm in case of an emergency;
- (e) a notice that elevators should not be used in case of fire unless otherwise instructed by the Fire Department;
- (f) the floor numbers.

The Fire Safety Coordinator must make sure that all posted fire safety signs are clearly visible. He/she must also make sure that exit signs posted above doors are always illuminated. Examples of some of these signs are shown on the next page.

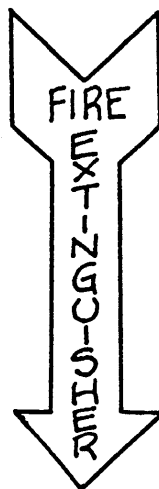
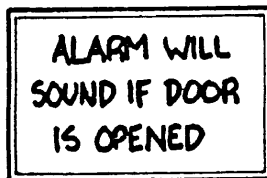
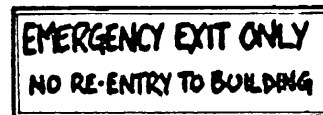
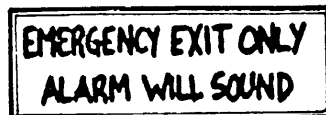

STAIRWELL AND ELEVATOR BANK IDENTIFICATION



(POSTED BY OUTSIDE OF DOOR)

FLOOR LEVEL IDENTIFICATION

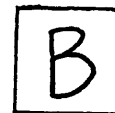

(POSTED BY DOOR INSIDE OF STAIRWELL)

Safety signs must be posted at several locations throughout the shelter. A sign must be posted on every floor inside the stairways and next to each elevator. The sign must indicate number of the floor. It must also indicate the location of the elevators and the stairways. Typical signs are illustrated below.

"FLOOR 12, ELEVATOR A"

or

## **"FLOOR 10, STAIRWAY B"**

These signs make it easier for Fire Department personnel to identify the quickest route to a fire. It also allows the occupants to identify the exit stairs.

A sign must be posted on every floor at the elevator landing. This sign must indicate that the elevator must not be used in case of an emergency. For example, the sign might read:

**"IN CASE OF FIRE, USE STAIRS UNLESS OTHERWISE INSTRUCTED"**

This sign must also indicate the location of the stairways on the floor.

A sign must be posted in the stairway at every floor. The sign must indicate whether entry to the building is permitted from the floor. When entry is not permitted the sign must indicate the number of the floor where entry is permitted. For example, a typical sign might read:

**"RE-ENTRY  
ON THIS FLOOR"**

or

**"NO RE-ENTRY.  
NEAREST RE-ENTRY ON  
THE 7TH AND 10TH FLOORS"**

A sign must also be posted on the building side of the exit door. This sign must also indicate whether re-entry is permitted from the floor.

A sign must be posted on the inside of the door in each sleeping room. The sign must indicate the location of the rooms and the exits on the floor. This sign is used by the occupants of the room during an emergency. An example of a typical floor plan is shown below.



**A Typical Floor Plan**

Emergency instruction charts should be posted at several locations on the premises. An example of a typical emergency instruction chart is shown below.



## **KEEP POSTED AT FRONT DESK**

### **IN THE EVENT OF FIRE OR OTHER INCIDENT REQUIRING THE SERVICES OF THE FIRE DEPARTMENT**

1. **WITHOUT DELAY call the Fire Department at \_\_\_\_\_**
2. **Ascertain, if possible, information about the fire:**  
LOCATION – FLOOR – ROOM NUMBER – IS ROOM OCCUPIED – NUMBER OF OCCUPANTS
3. **Return elevators to the lobby and hold them for Fire Department use.**  
**NOTE: Elevators are not to be used by shelter occupants when there is a fire in the building unless their use is deemed to be safe by Fire Department officials.**
4. **Post a simple diagram at the front desk detailing the general layout of the Building. Indicate elevators and stairways. Indicate which stairways go to the roof and which stairways have standpipe risers.**
5. **Keep the telephone switchboard manned. Give priority to calls from the fire floor and the floor above. Prepare a list for the Fire Department of rooms in which persons report they are trapped by fire or smoke. If possible, provide an interpreter for non-English speaking occupants.**
6. **If smoke conditions are causing people to leave their rooms, direct them to two Floors below the fire, VIA STAIRWAYS.**
7. **Request police assistance to clear the lobby so Fire Department operations Will not be delayed.**
8. **Keep a supply of each typical floor plan at the fire command station for Fire Department use.**
9. **Keep a supply of master keys (minimum one set per floor) at the fire command Station for Fire Department use.**
10. **Have the Fire Safety Coordinator or other knowledgeable person meet the Fire Department when they arrive. Give them all available information, including Master keys and building floor plans.**

#### **TO REPORT A FIRE, DIAL 911 OR THE APPROPRIATE BOROUGH COMMUNICATION OFFICE (Insert appropriate telephone number in item No.1 above)**

Manhattan	(212) 999-2222
Queens	(718) 999-3333
Bronx	(718) 999-4444
Staten Island	(718) 999-5555
Brooklyn	(718) 999-6666

### **A Typical Emergency Instruction Chart**

Fire emergency instructions must also be posted in each room or office in the shelter. This sign must instruct the occupants how to behave in case of an emergency. The sign must also indicate the location of the room and the exits on the floor.

### **General Inspection Checklist**

Regular inspections and patrols of the premises are required. The Fire Safety Coordinator must make sure that these patrols are conducted. Generally, these patrols are conducted by the fire guard. Inspections may vary depending on the layout of the building; however, the following general guidelines may be used for all locations.

- (1) All exits, stairways, hallways must be kept free of obstructions. Obstructions may prevent occupants from exiting the building in case of an emergency. An exit aisle at least 3 feet wide between beds and four feet wide in the hallways must be maintained in these locations.
- (2) Self-closing doors must not be propped open. These doors are designed to close automatically in case of a fire. This prevents the spread of fire and smoke.
- (3) Locks, bolts, chains must not be installed on exits while there are people in the building. If locks are discovered they must be removed immediately.
- (4) The entire premises must be checked daily for potential sources of fire. Any potential source that is discovered must be corrected or removed immediately. For example, frayed electrical wires and defective electronic components must be either repaired or removed.
- (5) Trash or garbage must not be allowed to accumulate anywhere inside the building. Accumulated trash is a fire hazard. It may be easily ignited by a stray spark. All trash and garbage must be removed from the premises.

(6) All required Fire Department permits and certificates must be current. The results of all tests and inspections must be recorded in the inspection log. The log, permits and certificates must be made available to Fire Department representatives upon request.

(7) When sprinkler and/or standpipe systems are installed they must be visually inspected monthly. Defects must be corrected and recorded in the inspection log. Serious defects must be reported to the fire department. For example, a defective water control valve must be reported to the Fire Department. This will allow the Fire Department to modify its fire fighting strategies for the building.

(8) All fire extinguishers must be clearly visible. Signs must be posted indicating the location of the extinguishers. Signs indicating how to use the fire extinguishing devices must be posted also. The Fire Safety Coordinator must make sure that the extinguishers are recharged annually and after each time they are used.

### **FIRE EXTINGUISHING DEVICES**

The Fire Safety Coordinator must be familiar with the different types of fire extinguishers in the building. He/she must know how to operate the extinguishers in a safe and efficient manner. He/she must know the difference between the various types of extinguishers and when they may be used. A description of the four classes of fires and the appropriate extinguishers are described below.

**Class A** fires are caused by ordinary combustible materials (such as wood, paper, and cloth), for which the quenching-cooling effect of quantities of water or solutions containing large percentages of water is most effective in reducing the temperature of the burning material below its ignition temperature.

**Class B** fires are caused by flammable petroleum products or other flammable liquids, greases, etc., for which the blanketing-smothering effect of oxygen excluding media such as CO<sub>2</sub>, dry chemical or foam is most effective.

**Class C** fires involve electrical equipment. The electrical non-conductivity of the extinguishing media is of first importance. These fire must be extinguished with non-conductive media such as CO<sub>2</sub> or dry chemical.

**Class D** fires are caused by ignitable metals, such as magnesium, titanium, and metallic sodium, or metals that are combustible under certain conditions, such as calcium, zinc, and aluminum. Generally, water should not be used to extinguish these fires.

**Class K** fires are fires in cooking appliances that involve combustible cooking media (vegetable or animal oils and fats).

A Multi-purpose dry chemical fire extinguisher may be used to extinguish Class A, B, or C fires. Examples of several extinguishers are shown on the next page.

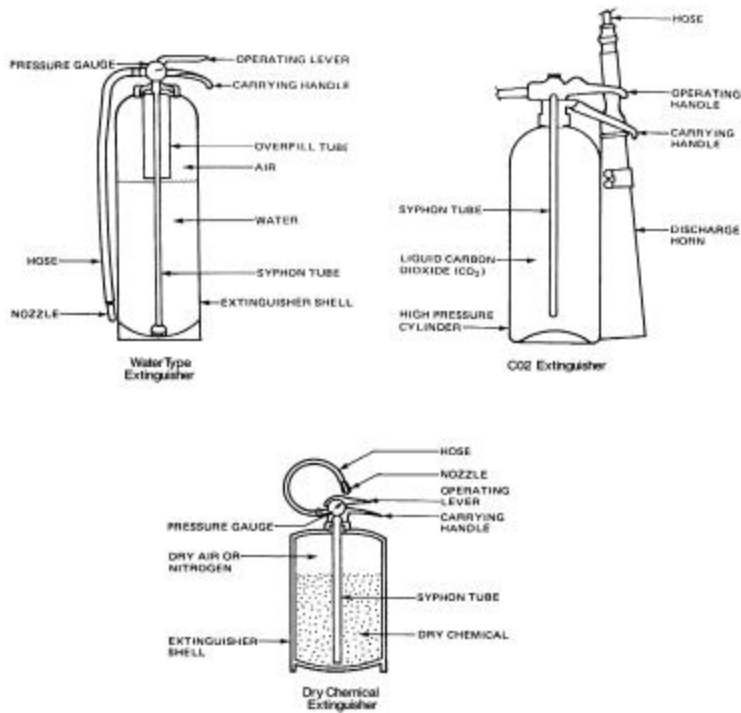

Symbols may also be painted on the extinguisher. They indicate what kind of fires the extinguishers may be used on. Examples of these symbols are shown below.

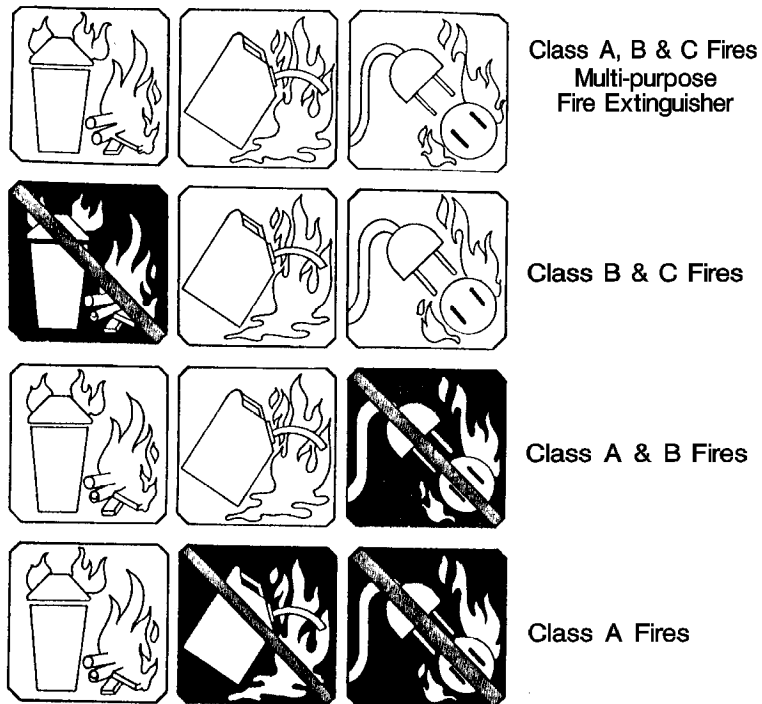

The symbol with the shaded background and the slash indicate when the extinguisher must not be used. The Fire Safety Coordinator must understand these symbols. The Fire Safety Coordinator must make sure that the fire extinguishers are kept in good working order at all times.

Usually, operating instructions are clearly painted on the side of the fire extinguisher. They clearly describe how to use the extinguisher in case of an emergency. An example of these instructions is shown below.



### **Fire Extinguisher Inspections**

The Fire Safety Coordinator must make sure that the fire extinguishers are visually inspected monthly. This inspection can be performed by the Fire Safety Coordinator. When a damaged extinguisher is discovered it must be repaired or replaced immediately. Care must be taken to make sure that all the fire extinguishers are fully charged. This is checked by looking at the gage connected to the top of the extinguisher. A needle indicating the condition of the extinguisher is positioned inside the gage. When the needle points to the green area the extinguisher is fully charged. When the needle points to the red area the extinguisher must be recharged.

The Fire Safety Coordinator must make arrangements to recharge the extinguisher when required. A qualified technician with a Certificate of Fitness for the Servicing of Portable Fire Extinguishers must recharge the extinguishers when necessary. Additionally, the Fire Safety Coordinator must make arrangements to have all extinguishers maintained at least once a year by a qualified technician holding a Certificate of Fitness for the Servicing of Portable Fire Extinguishers. The maintenance date, the name of the technician servicing the extinguisher, the certificate number, and the name, address and phone number of the servicing company must be recorded on a tag attached to the extinguisher. All inspections, maintenance, and/or recharging must be recorded in the inspection log.

### **Portable Fire Extinguisher Distribution**

Portable fire extinguishers must be placed so that they are clearly visible. In shelters, one approved-type portable fire extinguisher must be provided for every 2,500 square feet of floor area or part thereof on every floor. One approved class K type fire extinguisher must be provided for each 30 square feet of kitchen floor space.

### **GENERAL SAFEGUARDS**

Flammable and combustible materials must be stored in a safe location. This location must be free of sources of heat and ignition. It is recommended that these materials be stored in an outdoor location.

The Fire Safety Coordinator must make sure that no smoking is permitted in designated **NO SMOKING** areas. This is especially important in areas where flammable or combustible materials are stored.

The Fire Safety Coordinator must make sure that only approved electrical devices are used. Frayed wires, defective appliances and other potential sources of electrical fire must be repaired or replaced. The Fire Safety Coordinators must report any life threatening fire hazards to the Fire Department immediately.

## **APPENDIX A**

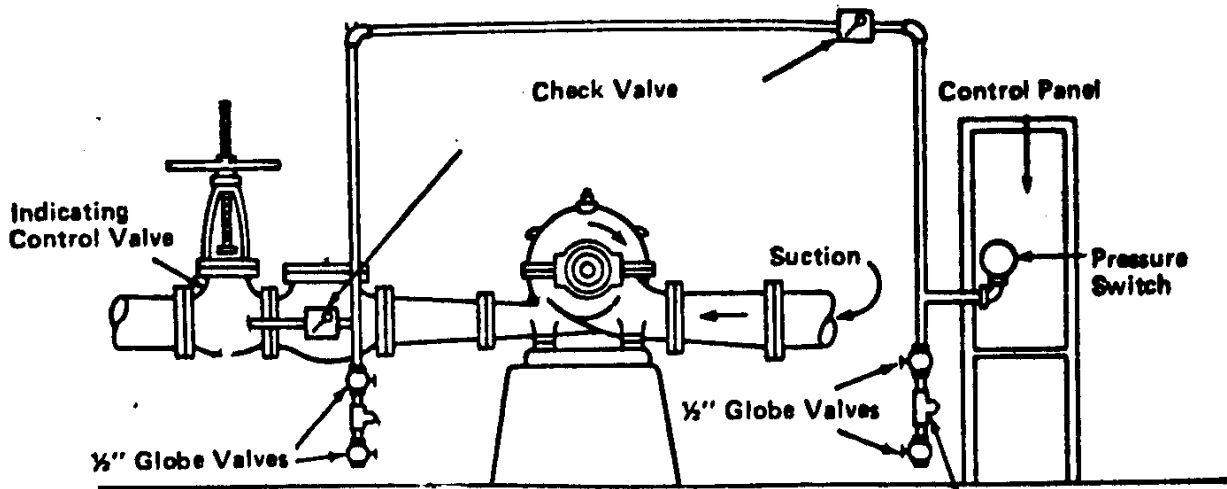

Typical Fire Pump

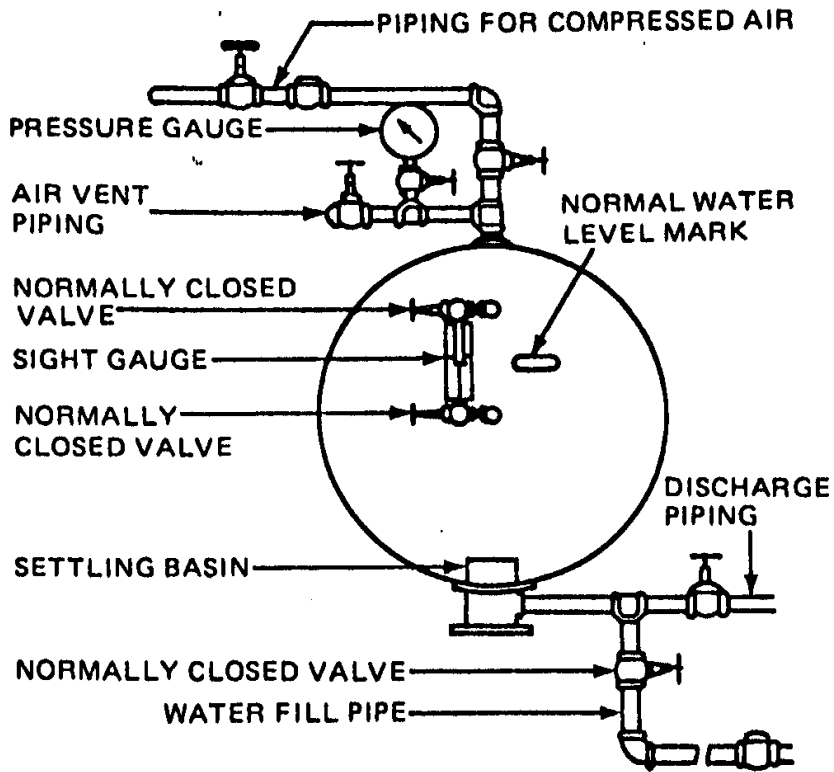

Typical Pressure Tank

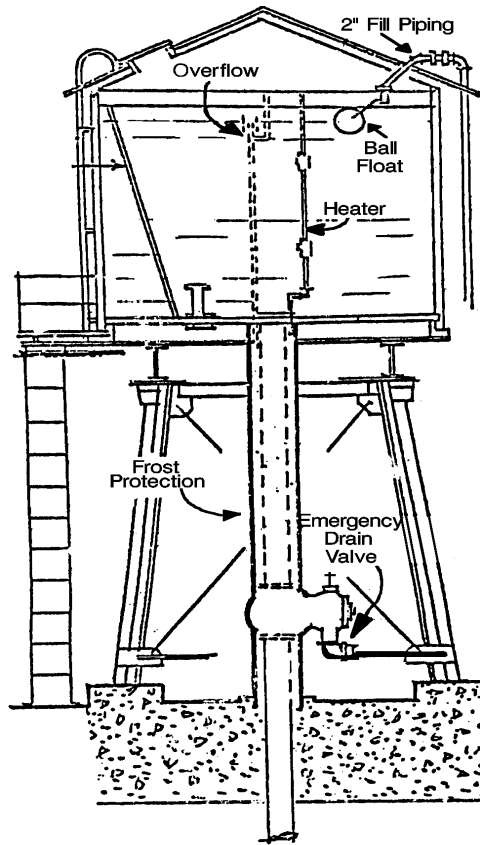

**Typical Gravity Tank**



**Typical Siamese Connection**

Parts of a Typical Siamese Connection

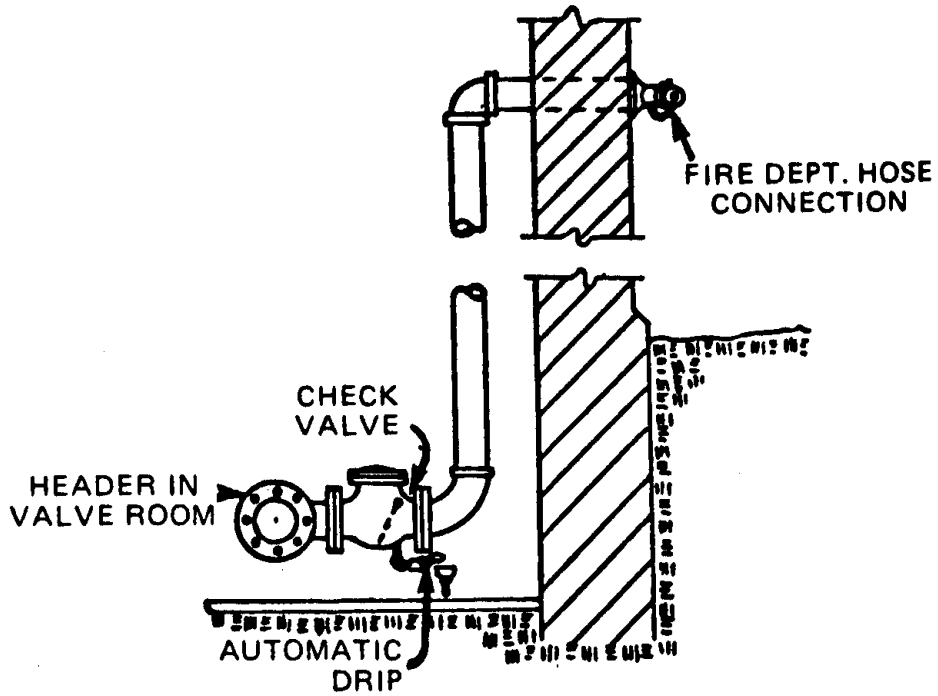

A typical wet pipe sprinkler valve

